



Filter Wheel Assembly



Filter wheel assemblies are essential in uniform source systems for two reasons: input sources and detector monitors. It is often a requirement for applications that the user requires a very specific spectrum or band of input to their device under test, a filter wheel can be employed to give them options for spectral selection into the HSA spheres. In the opposite approach, a broadband source (like QTH or Plasma) is employed in the sphere and the device under test may have specific spectral bands of interest. A filter wheel can be deployed at the detector locations to selectively filter for bands of interest. Labsphere has designed the filter wheel assemblies to provide flexibility in size and application with the HELIOS modular system configurations.

VALUE

1" and 2" wheels with (8) and (5) positions respectively

Removeable wheel cartridges from housing with Intelligent Wheel recognition – multiple wheels may be employed in the same housing without removing the wheel from the sphere

Optional hand controller available (recommend control through HELIOSense Software)

Specifications

Models

Part #	HFW-1-8 AS-03046-100	HFW-2-5 AS-03046-200
Filter Size:	1" Diam. (25mm, unmounted)	2" Diam. (50mm, unmounted)
# of Positions:	(8)	(5)
Typical Use/Mount Location:	Detector Position	Source Position
Maximum Filter Thickness:	0.25" (7mm)	0.25" (7mm)
Filter Mount Ring:	(8) Included	(5) Included
Communication Cable:	(1) 6' USB Cable	(1) 6' USB Cable
Motor Control Cable:	(1) 12' RJ45 Cable.	(1) 12' RJ45 Cable.
Operating Temperature Range:	10 to 100C	10 to 100C
Storage Temperature Range:	-20C to 70C	-20C to 70C
HFW Operating RH%:	30-90% (no condensation)	30-90% (no condensation)
Remmended RH% for Filters:	<50% Humidity - NO Condensation.	<50% Humidity - NO Condensation.
Storage RH%:	10-95% (no condensation)	10-95% (no condensation)
Compliance:	CE, RoHS	CE, RoHS
Standard Warranty:	1 year	1 year



HFW-1-8 Dimensional Drawing

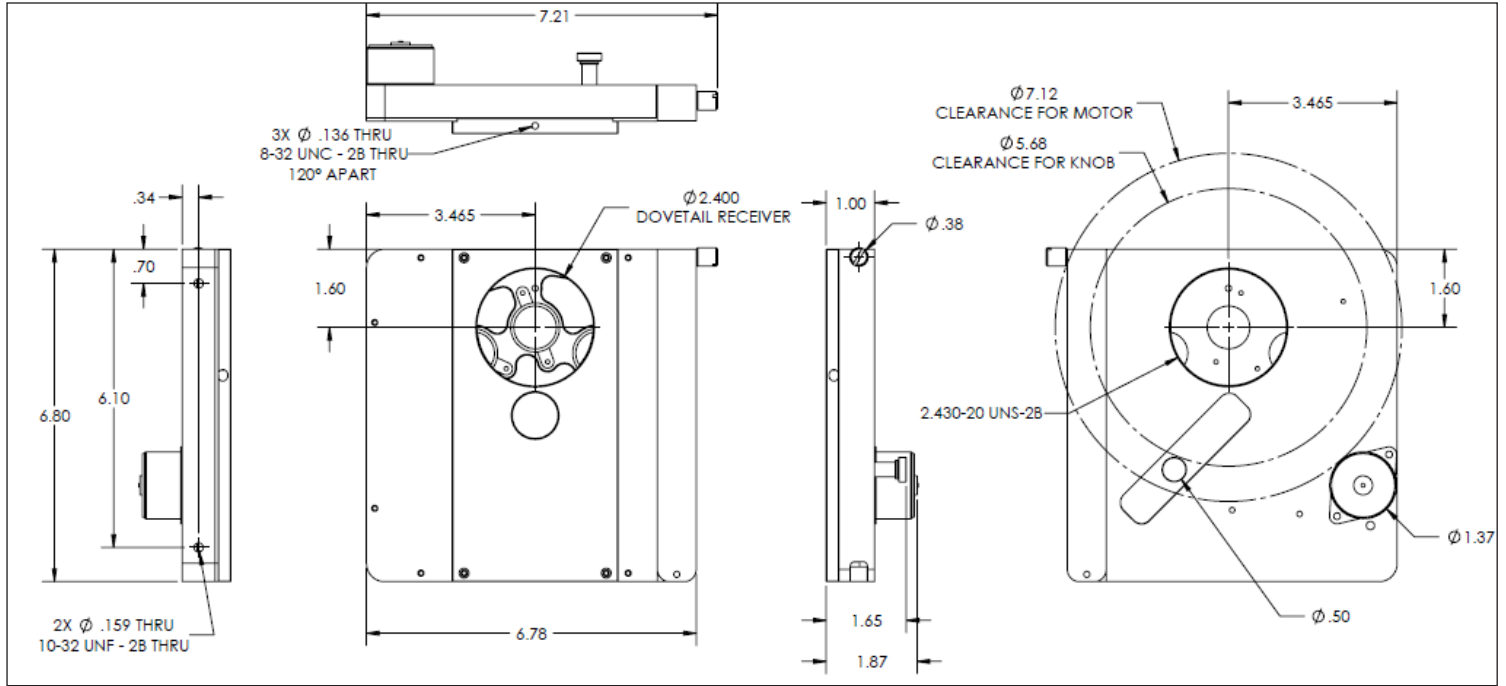

HFW-2-5 Dimensional Drawing

